



Technical comercial data

N-10 T.N-10-O

Serie NOVA – Versión 31-05-2023

TECHNICAL DATA:

Material: PP copolymer of first quality, suitable for contact with food according to current regulations.

Colours: White standard. Consult for other colours.

Useful Volume: 10 litres
Volume to the edge: 11.9 litres

Weight of the bucket: 357 g. approx.
Weight of the lid (with berg): 141 g. approx.
Weight of the handle: - metal: 55 g. approx.
- plastic: 3 g. approx.
Total Weight: 556 g. approx.

Decorative surface flat inks: 170 x 779 mm (height x perimeter)
Design surface photographic finish: 175 x 795 mm (height x perimeter)



MEASUREMENTS:

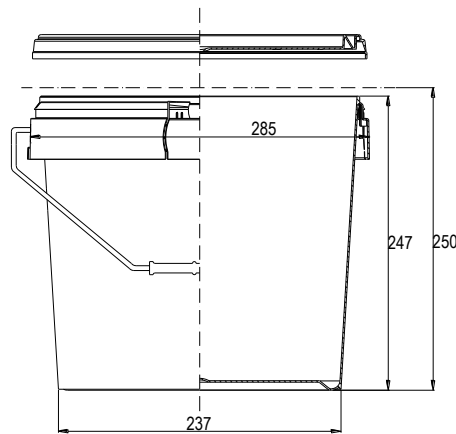

Measurements in millimetres

GROUPING OF TRANSPORT:

Buckets: 480 buckets per pallet
Pallet dimensions: 1150 x 850 x 1685 (see drawing)

Lids: 80 lids per box, this serves as a packaging of transportation

Box dimension: 290 x 290 x 1070

